

VL CONNECTOR

Disconnectable Crimp style connectors

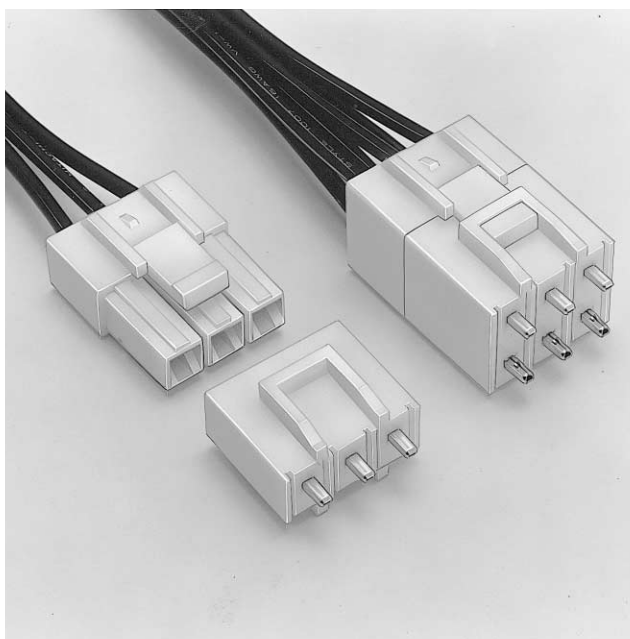

This VL connector is designed for wire-to-wire and wire-to-board 6.2mm (.244") pitch connector corresponding to large current. Secondary retainer, which prevents from insufficient insertion of contact and coming off contact, may use and large current circuit can be connected certainly and safety.

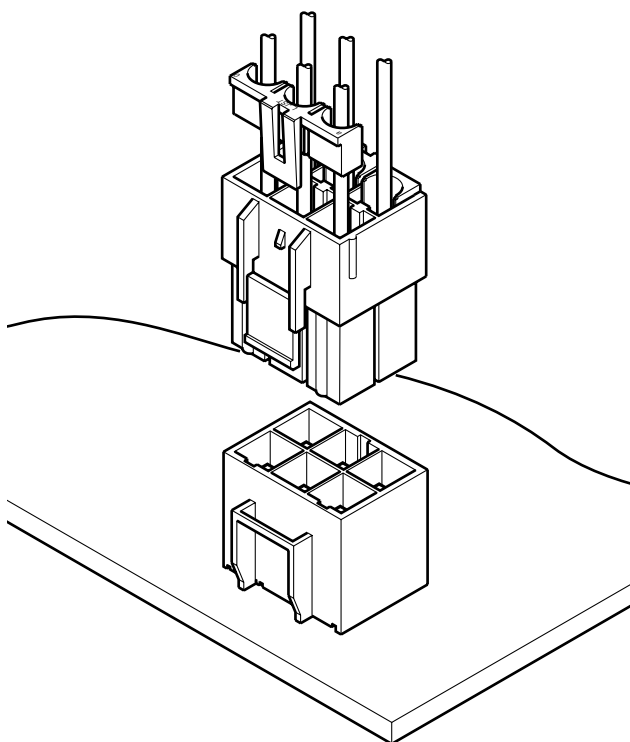

Features

• Housing lances for contact retention

Since the contact retention lances are part of the housing rather than protruding from the contact, they cannot be damaged by handling. They allow the contact to be easily inserted and securely locked into the housing.

• Secondary retainer

The secondary retainer is optionally available. This retainer ensures that the contacts are fully seated and locked in the housing and prevents their accidental release. Installed after the contacts are inserted, the secondary retainer locks and secures the contacts.

• Suited for large current

Since these contacts have large cross-sectional areas and high contact pressure, they can accommodate large current.

• Two kinds of connections

The VL connectors can be used for wire-to-wire or wire-to-board connections.

Specifications

- Current rating: 20A AC, DC (Refer to the table below.)
- Voltage rating: 600V AC, DC
- Temperature range: -25°C to +90°C (including temperature rise in applying electrical current)
- Contact resistance: Initial value/7m Ω max. After environmental testing/10m Ω max.
- Insulation resistance: 1,000M Ω min.
- Withstanding voltage: 2,000V AC/minute
- Applicable wire: AWG #22 to #12
- Applicable PC board thickness: 1.6mm(.063")
- * Contact JST if Lead-Free product is required.
- * Temperature Range: The aforementioned temperature range of this connector is described in JST Standard Product Specification. Maximum temperature registered in UL is 105°C.
- * Refer to "General Instruction and Notice when using Terminals and Connectors" at the end of this catalog.
- * Contact JST for details.

Note:

The current rating differs depending on the number of circuits and the wire size used in each connector. The table below lists the current rating as a function of the number of circuits and the wire size.

Current unit:A

Circuits	Wire size(AWG)					
	#12	#14	#16	#18	#20	#22
*2(3)	20	15	10	8	6	4
3	17	14	9	8	6	4
4	16	13	9	7	6	4
6	15	12	8	7	5	3
8	14	11	7	6	5	3
12	13	10	7	6	4	3

Note:

Do not branch in parallel current which exceeds the rated current (eg. more than 17A in the case of 3 circuits with AWG #12). If branched in parallel, current imbalance or other problems may develop. If it is absolutely necessary to branch such a large current in parallel, design the circuits without causing any imbalance and provide an extra margin for each circuit.

Standards

Recognized E60389 Certified LR20812 R9351103

JST 245

VL CONNECTOR

Contact

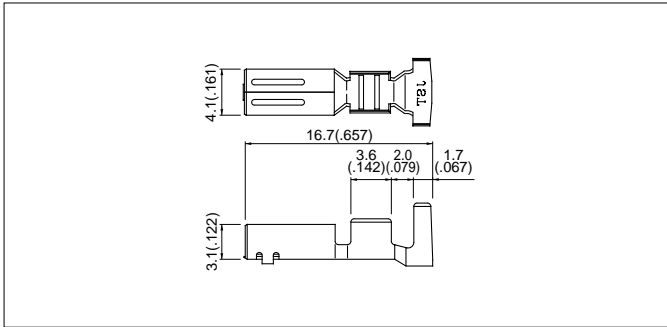

Model No.	Applicable wire			Qty / reel
	mm ²	AWG #	Insulation O.D. mm(in.)	
SVF-42T-P2.0	0.3 to 1.25	22 to 16	1.7 to 3.2(.067 to .126)	2,000
SVF-61T-P2.0	0.5 to 2.0	20 to 14	1.9 to 3.4(.075 to .134)	2,000
SVF-81T-P2.0	3.5	12	4.1(.161)	2,000

Material and Finish

Phosphor bronze, tin-plated

Note: SVF-42T-P2.0 is not TÜV approved.

Housing (Inner-housing lock)

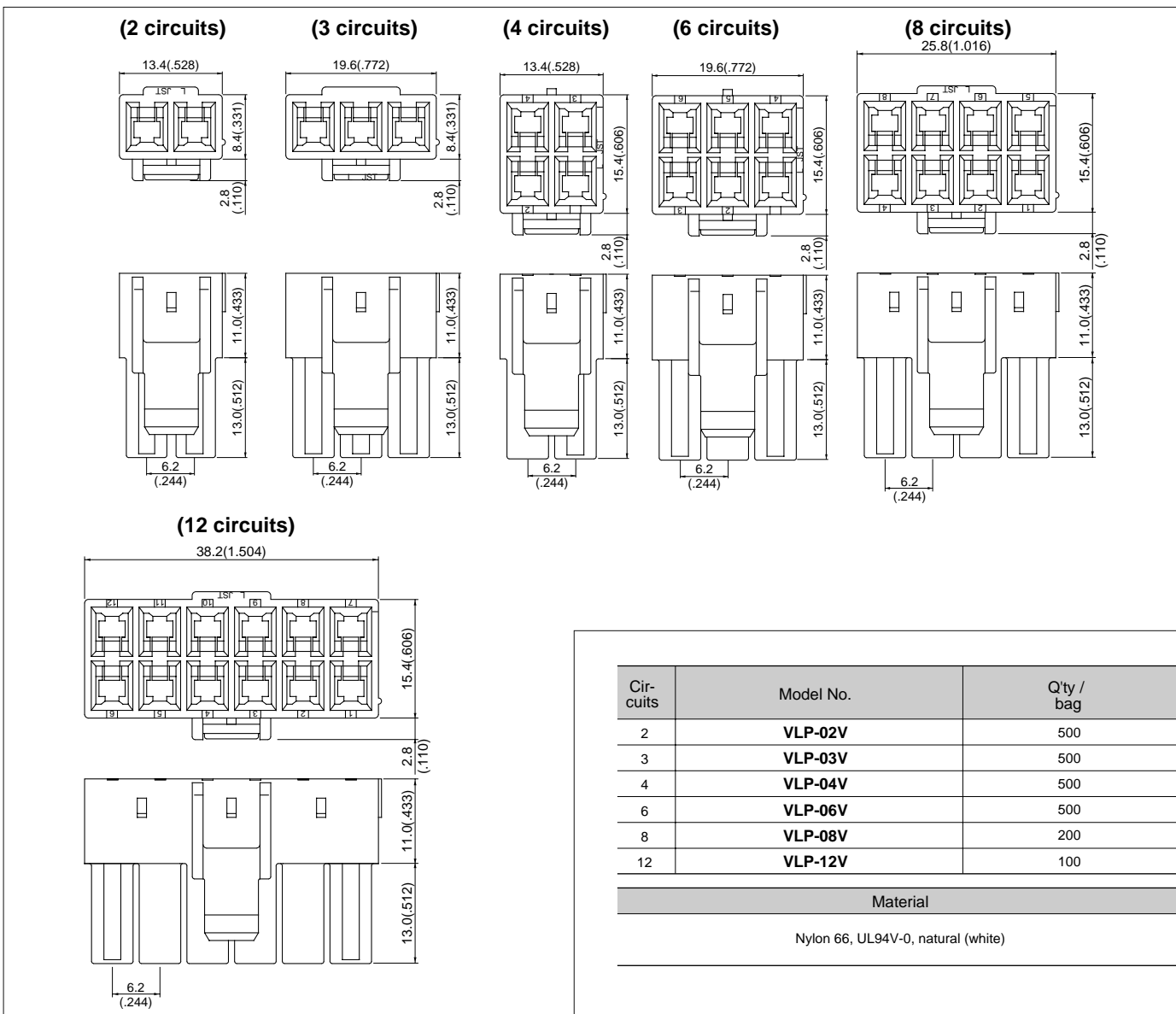

Circuits	Model No.	Qty / bag
2	VLP-02V	500
3	VLP-03V	500
4	VLP-04V	500
6	VLP-06V	500
8	VLP-08V	200
12	VLP-12V	100

Material

Nylon 66, UL94V-0, natural (white)

Housing (Outer-housing lock)

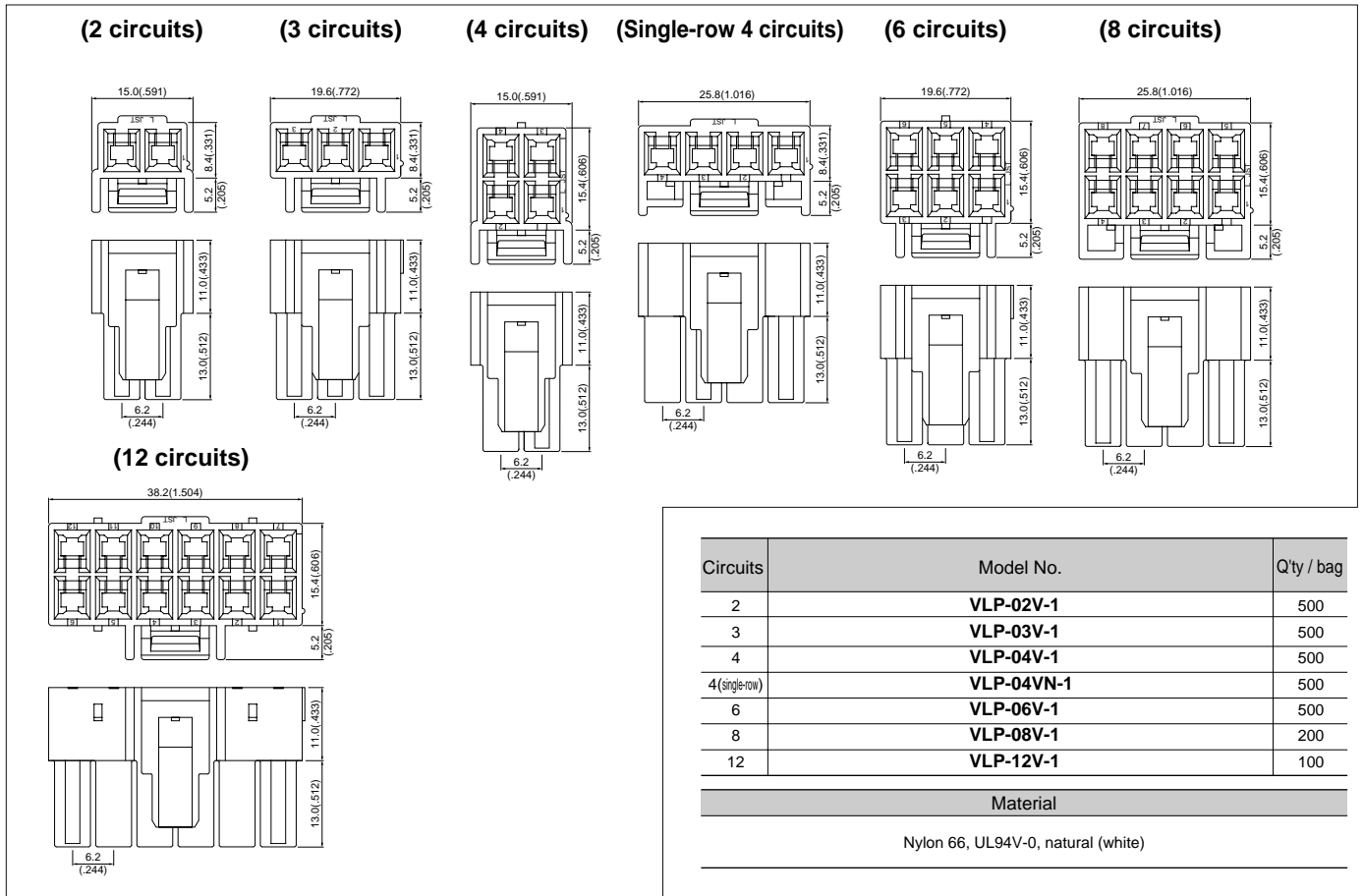

Retainer

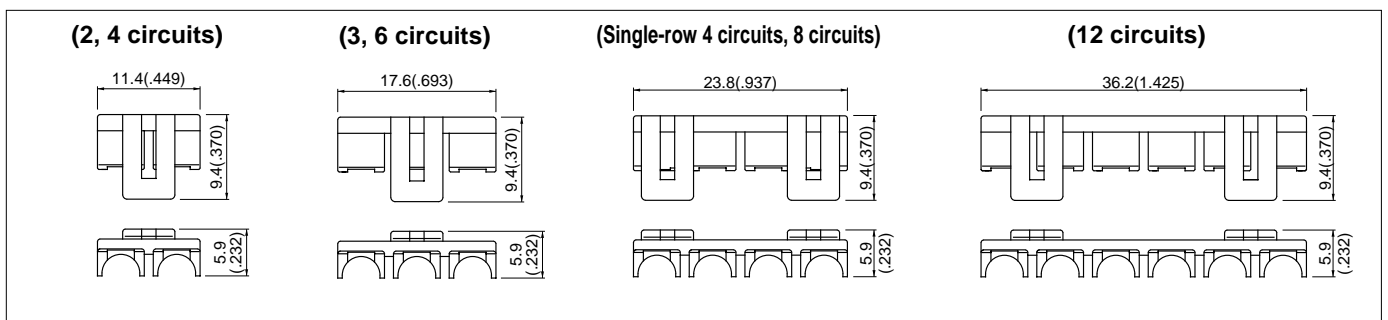

Circuits	Model No.	Qty / bag
2, 4	VLS-02V	1,000
3, 6	VLS-03V	1,000
4 (single-row), 8	VLS-08V	1,000
12	VLS-12V	1,000

Material		
Glass-filled nylon 66, UL94V-0, natural (ivory)		

Glass-filled nylon 66, UL94V-0, natural (ivory)

VL CONNECTOR

Shrouded header

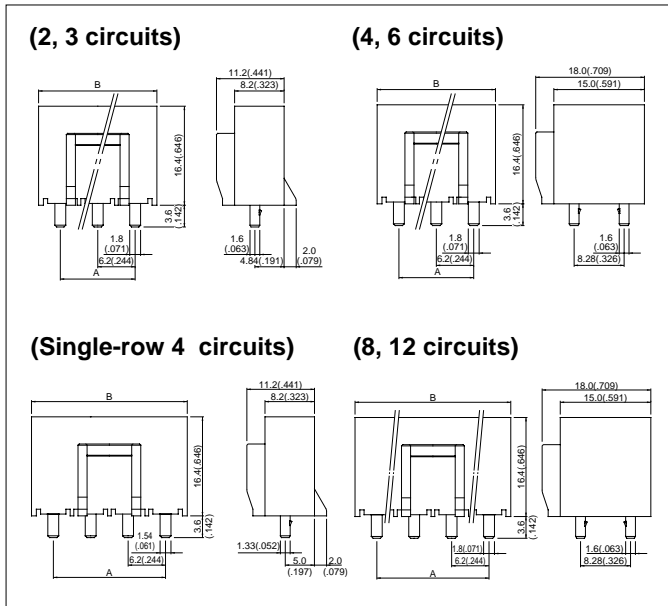

Circuits	Model No.	Dimensions mm(in.)		Q'ty / box
		A	B	
2	B02P-VL	6.2(.244)	13.4(.528)	100
3	B03P-VL	12.4(.488)	19.6(.772)	100
4	B04P-VL	6.2(.244)	13.4(.528)	100
4(single-row)	B04P-VL-VN-1.8	18.6(.732)	26.2(1.031)	100
6	B06P-VL	12.4(.488)	19.6(.772)	50
8	B08P-VL	18.6(.732)	26.2(1.031)	50
12	B12P-VL	31.0(1.220)	38.6(1.520)	40

Material and Finish

Post: Copper-alloy, tin-plated
Wafer: Nylon 66, UL94V-0, natural (white)

Contact position location numbers

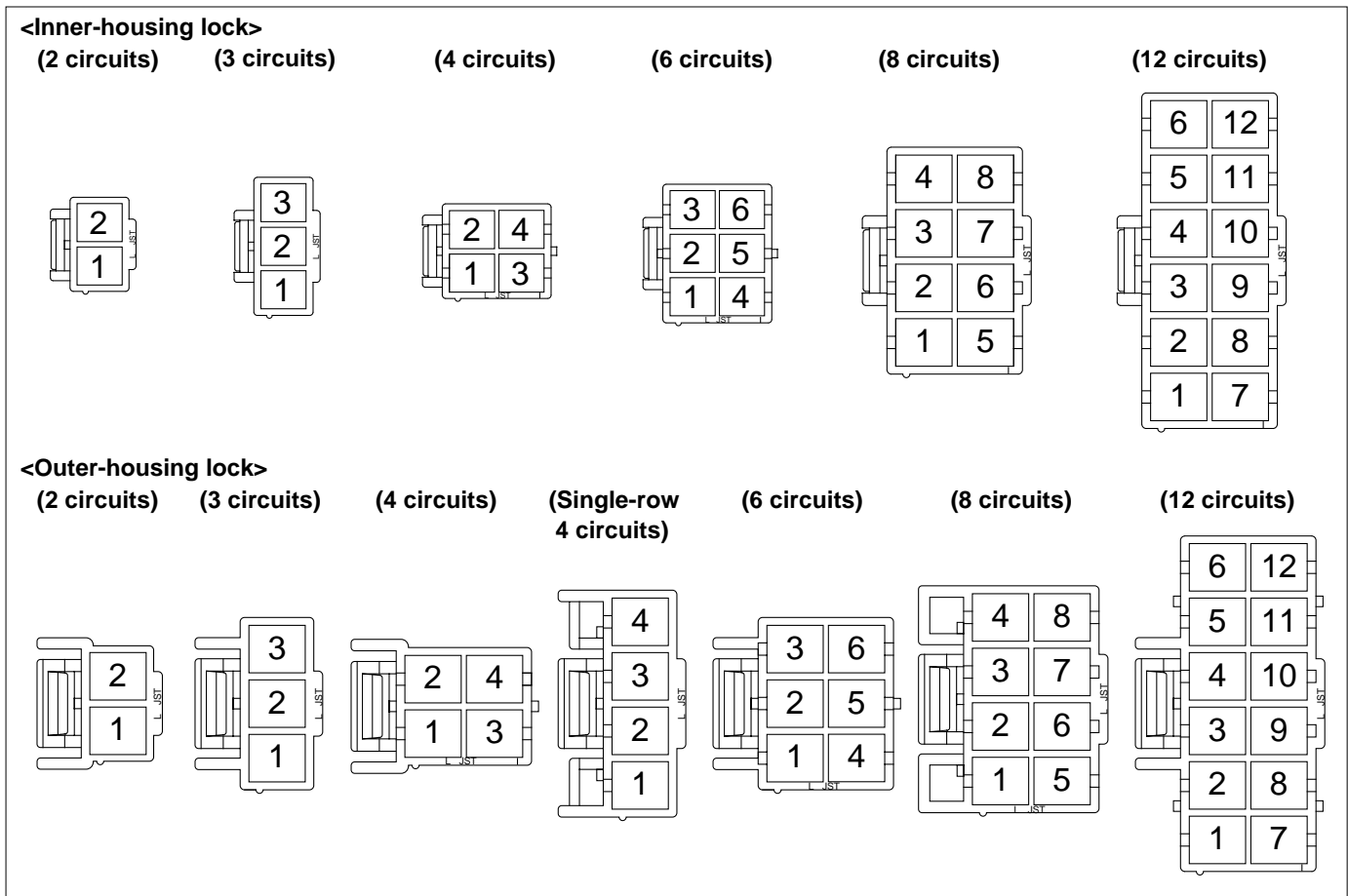

PC board layout (viewed from soldering side) and Assembly layout

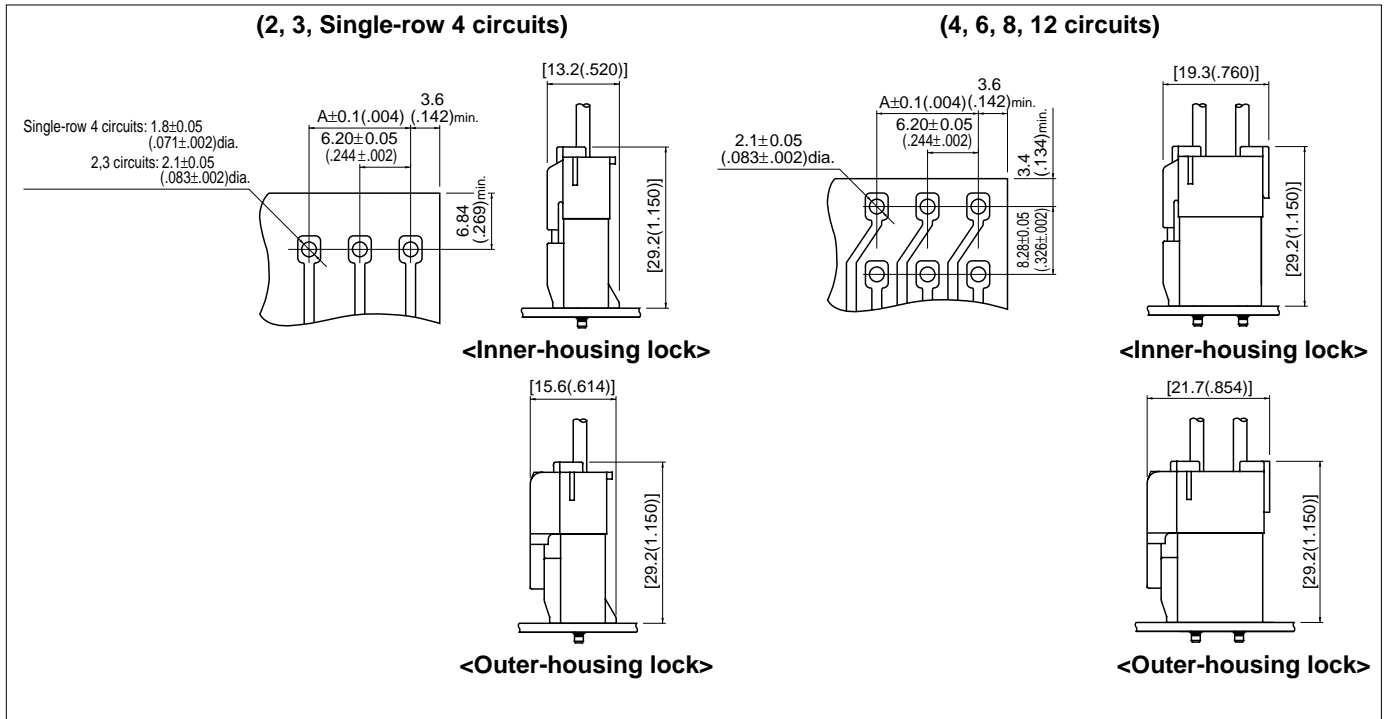

Note:

1. Tolerances are non-cumulative: $\pm 0.05\text{mm}$ ($\pm .002''$) for all centers.
2. Hole dimensions differ according to the kind of PC board and piercing method. The dimensions above should serve as a guideline. Contact JST for details.

Applicator for the semi-automatic press AP-K2N

Contact	Crimp applicator MKS-L		Compact crimp applicator MKS-LS		Strip-crimp applicator MKS-SC
	with safety cover	without safety cover	with safety cover	without safety cover	with safety cover
SVF-42T-P2.0	APLMK SVF/M42-20	APLNC SVF/M42-20	-	-	-
SVF-61T-P2.0	APLMK SVF/M61-20	APLNC SVF/M61-20	-	-	-
SVF-81T-P2.0	APLMK SVF/M81-20	APLNC SVF/M81-20	-	-	-